



EC057C Series

The EC057C Series Brushless DC Motor is a high torque density model brushless motor in a NEMA 23 configuration. It is offered in 4 motor lengths with continuous torque from 0.078 – 0.28 Nm.

EC Instrument Grade Motors

For applications that require uniform motion control at all speeds. Capable of high acceleration.

Benefits

- Speeds up to 12,000 RPM possible
- DC bus voltage up to 76.4 VDC
- NEMA 23 configuration
- Eight standard windings per stack, special windings available
- 4 Pole rare earth design

Optional Assemblies

- Encoder: E30C/D
- Gearboxes: G40A, PLG42S, G51A, PLG52
- Brake: B49A
- Programmable Drives: BGE3004A, BGE6015A

Motor Characteristics

Motor Data	Units	Part No.			
		EC057C-1	EC057C-2	EC057C-3	EC057C-4
Max DC Terminal Voltage	V_T	90			
Max Speed (Mechanical)	ω_{MAX}	12000			
Continuous Stall Torque ¹	T_{CS}	0.078	0.14	0.22	0.28
		11	20	31	40
Peak Torque (Maximum) ¹	T_{pk}	0.25	0.44	0.70	0.88
		36	63	99	130
Coulomb Friction Torque	T_f	0.0066	0.0078	0.0092	0.011
		0.93	1.1	1.3	1.5
Viscous Damping Factor	D	8.1E-07	2.1E-06	3.5E-06	4.9E-06
		0.012	0.031	0.052	0.072
Thermal Time Constant	τ_{th}	13	17	21	25
Thermal Resistance	R_{th}	11	7.9	5.2	4.7
Max. Winding Temperature	Θ_{MAX}	130	130	130	130
Rotor Inertia	J_r	4.2E-06	7.8E-06	1.1E-05	1.5E-05
		6.0E-04	0.0011	0.0016	0.0021
Motor Weight	W_m	370	510	670	830
		13	18	24	29

¹Recorded at maximum winding temperature at 25°C ambient and without heatsink.

Dimensional Drawings: EC057C-1 • EC057C-2 • EC057C-3 • EC057C-4

Dimensions = inches (mm)

L = Lengths Available
 EC057C-1 = 1.464 (37.19) Max.
 EC057C-2 = 1.914 (48.62) Max.
 EC057C-3 = 2.414 (61.32) Max.
 EC057C-4 = 2.914 (74.02) Max.

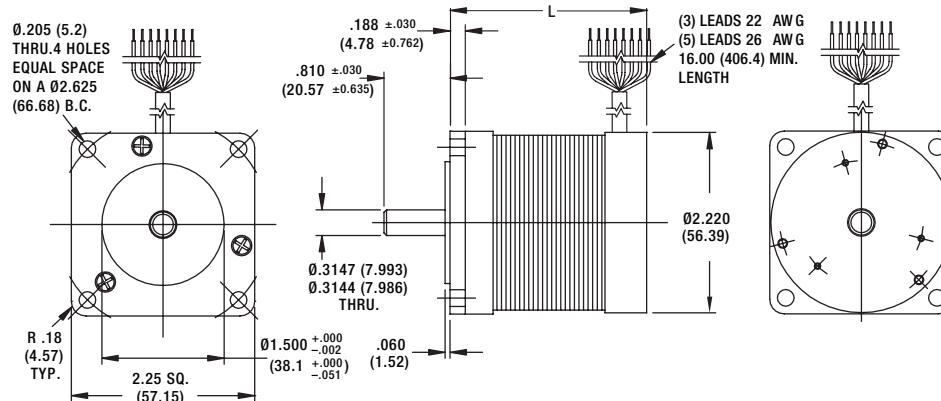

Motor Data		Units								
Rated Voltage V1	V_r	V	9.55	12.0	15.2	19.1	24.0	30.3	38.2	48.0
Rated Torque ¹ •	T_r	Nm	0.071	0.070	0.069	0.068	0.068	0.067	0.067	0.067
		oz-in	10	9.9	9.7	9.6	9.6	9.5	9.5	9.5
Rated Speed ¹	ω_r	rpm	6290	6260	6590	6700	6540	6740	6820	6590
Rated Current ¹	I_r	A	7.2	5.5	4.4	3.5	2.7	2.1	1.7	1.3
Rated Power ¹	P_r	W	47	46	47	48	46	47	48	46
No Load Speed	ω_{nl}	rpm	7610	7360	7580	7630	7390	7580	7630	7380
No Load Current	I_{nl}	A	0.62	0.48	0.39	0.31	0.24	0.20	0.16	0.12
Rated Voltage V2	V_r	V	6.00	7.58	9.55	12.0	15.2	19.1	24.0	30.3
Rated Torque ¹ •	T_r	Nm	0.077	0.076	0.076	0.075	0.075	0.075	0.075	0.075
		oz-in	11	11	11	11	11	11	11	11
Rated Speed ¹	ω_r	rpm	3070	3180	3380	3460	3440	3540	3570	3480
Rated Current ¹	I_r	A	7.8	5.9	4.8	3.8	2.9	2.4	1.9	1.4
Rated Power ¹	P_r	W	25	25	27	27	27	28	28	27
No Load Speed	ω_{nl}	rpm	4740	4620	4730	4760	4650	4750	4770	4630
No Load Current	I_{nl}	A	0.60	0.46	0.38	0.30	0.23	0.19	0.15	0.12
Motor Constant	K_M	Nm/ \sqrt{W}	0.025	0.027	0.027	0.028	0.028	0.028	0.028	0.029
		oz-in/ \sqrt{W}	3.5	3.8	3.8	3.9	4.0	4.0	4.0	4.1
Torque Constant	K_T	Nm/A	0.0117	0.0153	0.0188	0.0235	0.0305	0.0375	0.0470	0.0610
		oz-in/A	1.66	2.16	2.66	3.33	4.31	5.31	6.65	8.64
Voltage Constant	K_E	V/(rad/s)	0.0117	0.0153	0.0188	0.0235	0.0305	0.0375	0.0470	0.0610
		V/krpm	1.23	1.60	1.97	2.46	3.19	3.93	4.92	6.39
Terminal Resistance	R_{mt}	Ω	0.220	0.330	0.480	0.730	1.16	1.77	2.76	4.50
Inductance	L	mH	0.24	0.41	0.62	0.97	1.6	2.5	3.9	6.5
Peak Current	I_{pk}	A	25	19	15	12	9.6	7.8	6.3	4.8
Electrical Time Constant	τ_e	ms	1.1	1.2	1.3	1.3	1.4	1.4	1.4	1.5
Mechanical Time Constant	τ_m	ms	6.8	6.0	5.8	5.6	5.3	5.3	5.3	5.1

¹Recorded at maximum winding temperature at 25°C ambient and without heatsink.

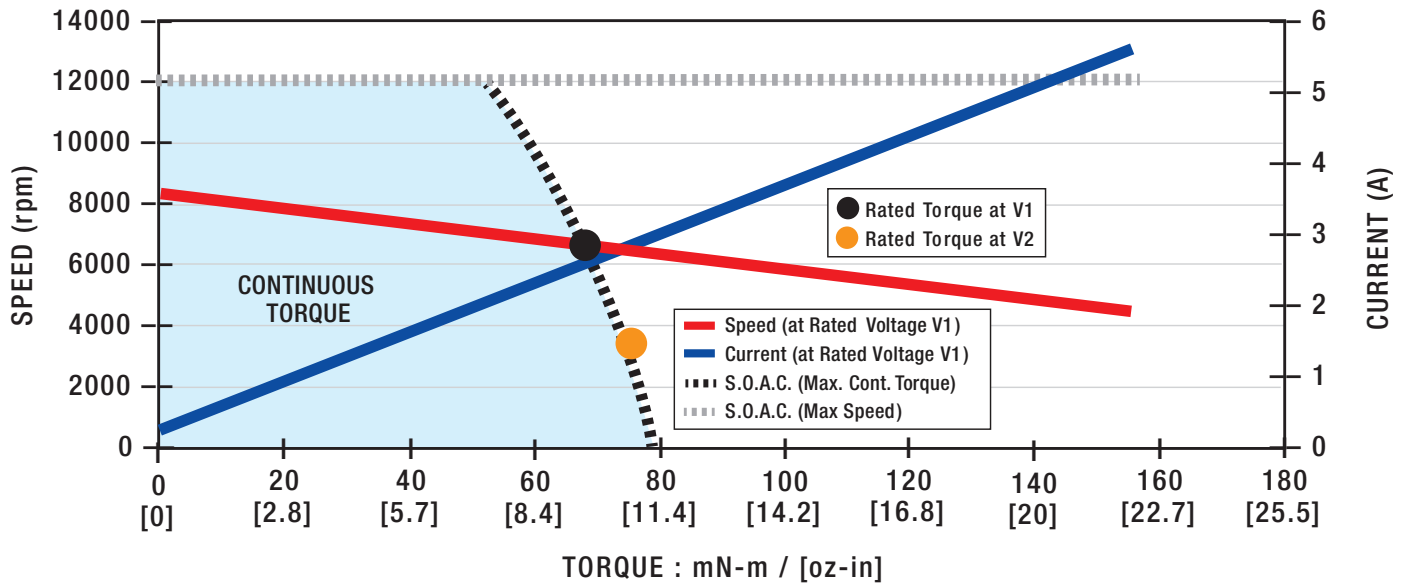

Motor Data		Units								
Rated Voltage V1	V_r	V	12.0	15.2	19.1	24.0	30.3	38.2	48.0	60.6
Rated Torque ¹ •	T_r	Nm	0.13	0.13	0.13	0.13	0.13	0.13	0.13	0.13
		oz-in	19	18	18	18	18	18	18	18
Rated Speed ¹	ω_r	rpm	5690	5890	5780	5980	6090	5930	6070	6070
Rated Current ¹	I_r	A	8.9	7.1	5.4	4.3	3.4	2.6	2.1	1.7
Rated Power ¹	P_r	W	79	80	78	80	81	78	80	80
No Load Speed	ω_{nl}	rpm	6620	6730	6490	6630	6700	6500	6640	6690
No Load Current	I_{nl}	A	0.54	0.44	0.34	0.27	0.22	0.17	0.14	0.11
Rated Voltage V2	V_r	V	7.58	9.55	12.0	15.2	19.1	24.0	30.3	38.2
Rated Torque ¹ •	T_r	Nm	0.14	0.14	0.14	0.14	0.14	0.14	0.14	0.14
		oz-in	20	20	20	20	20	20	19	20
Rated Speed ¹	ω_r	rpm	2970	3100	3080	3260	3310	3220	3320	3310
Rated Current ¹	I_r	A	9.5	7.6	5.8	4.6	3.7	2.9	2.3	1.9
Rated Power ¹	P_r	W	44	45	45	47	48	46	48	48
No Load Speed	ω_{nl}	rpm	4160	4210	4060	4180	4210	4070	4180	4210
No Load Current	I_{nl}	A	0.51	0.41	0.32	0.26	0.21	0.16	0.13	0.11
Motor Constant	K_M	Nm/ \sqrt{W}	0.039	0.040	0.042	0.043	0.043	0.044	0.044	0.044
		oz-in/ \sqrt{W}	5.6	5.7	6.0	6.1	6.1	6.3	6.3	6.2
Torque Constant	K_T	Nm/A	0.0171	0.0213	0.0278	0.0342	0.0427	0.0555	0.0683	0.0855
		oz-in/A	2.42	3.02	3.94	4.84	6.04	7.86	9.67	12.1
Voltage Constant	K_E	V/(rad/s)	0.0171	0.0213	0.0278	0.0342	0.0427	0.0555	0.0683	0.0855
		V/krpm	1.79	2.23	2.91	3.58	4.47	5.81	7.15	8.95
Terminal Resistance	R_{mt}	Ω	0.190	0.280	0.430	0.630	0.970	1.56	2.39	3.84
Inductance	L	mH	0.28	0.44	0.74	1.1	1.8	3.0	4.5	7.4
Peak Current	I_{pk}	A	30	24	18	15	12	9.3	7.5	6.0
Electrical Time Constant	τ_e	ms	1.5	1.6	1.7	1.8	1.8	1.9	1.9	1.9
Mechanical Time Constant	τ_m	ms	5.1	4.8	4.3	4.2	4.1	3.9	4.0	4.1

¹Recorded at maximum winding temperature at 25°C ambient and without heatsink.

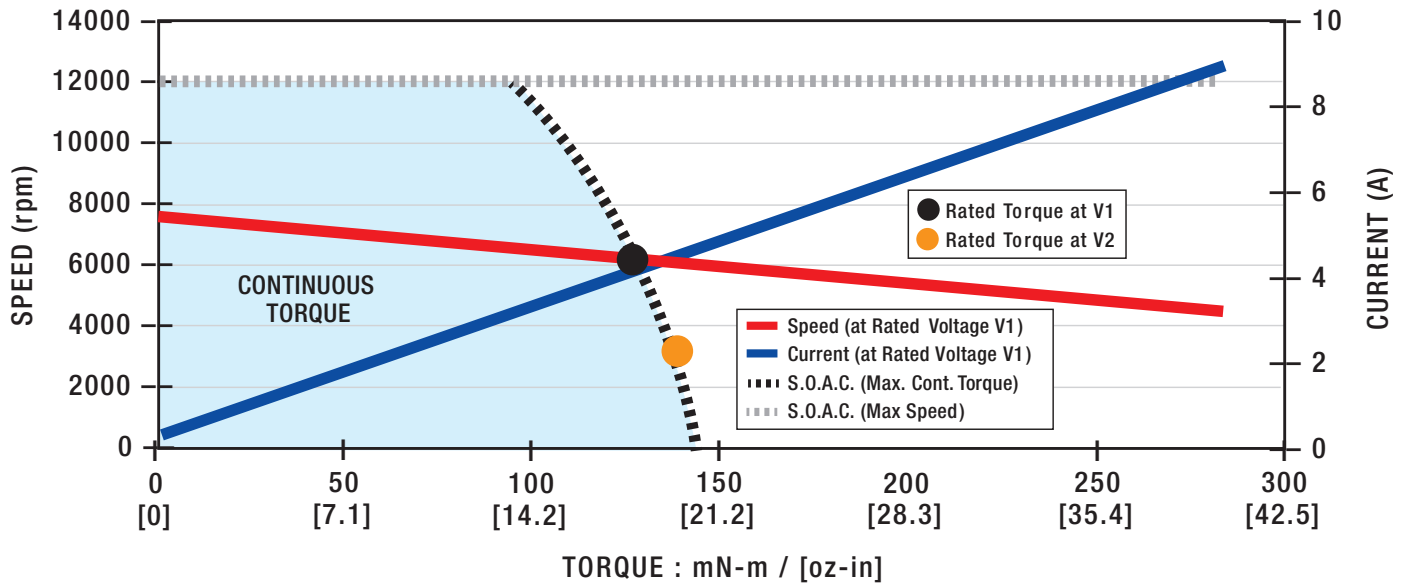

Motor Data		Units								
Rated Voltage V1	V_r	V	12.0	15.2	19.1	24.0	30.3	38.2	48.0	60.6
Rated Torque ¹ •	T_r	Nm	0.21	0.21	0.20	0.20	0.20	0.20	0.19	0.19
		oz-in	30	29	29	28	28	28	28	27
Rated Speed ¹	ω_r	rpm	5940	6060	6340	6470	6360	6570	6630	6460
Rated Current ¹	I_r	A	15	11	9.0	7.1	5.4	4.4	3.5	2.7
Rated Power ¹	P_r	W	130	130	130	140	130	130	140	130
No Load Speed	ω_{nl}	rpm	7060	6900	7060	7100	6890	7070	7090	6880
No Load Current	I_{nl}	A	0.74	0.57	0.47	0.37	0.29	0.23	0.19	0.15
Rated Voltage V2	V_r	V	7.58	9.55	12.0	15.2	19.1	24.0	30.3	38.2
Rated Torque ¹ •	T_r	Nm	0.22	0.22	0.22	0.22	0.22	0.21	0.21	0.21
		oz-in	31	31	31	31	30	30	30	30
Rated Speed ¹	ω_r	rpm	3080	3220	3430	3590	3540	3650	3720	3630
Rated Current ¹	I_r	A	16	12	9.6	7.7	5.8	4.7	3.8	2.9
Rated Power ¹	P_r	W	71	74	78	81	80	82	83	81
No Load Speed	ω_{nl}	rpm	4450	4330	4430	4490	4330	4430	4470	4330
No Load Current	I_{nl}	A	0.68	0.52	0.43	0.34	0.26	0.22	0.17	0.13
Motor Constant	K_M	Nm/ \sqrt{W}	0.046	0.051	0.052	0.054	0.057	0.057	0.058	0.059
		oz-in/ \sqrt{W}	6.6	7.2	7.4	7.7	8.0	8.1	8.1	8.3
Torque Constant	K_T	Nm/A	0.0160	0.0208	0.0256	0.0320	0.0416	0.0512	0.0641	0.0834
		oz-in/A	2.27	2.95	3.62	4.53	5.90	7.25	9.07	11.8
Voltage Constant	K_E	V/(rad/s)	0.0160	0.0208	0.0256	0.0320	0.0416	0.0512	0.0641	0.0834
		V/krpm	1.68	2.18	2.68	3.35	4.36	5.36	6.71	8.73
Terminal Resistance	R_{mt}	Ω	0.120	0.170	0.240	0.350	0.540	0.810	1.24	2.00
Inductance	L	mH	0.17	0.28	0.42	0.66	1.1	1.7	2.6	4.5
Peak Current	I_{pk}	A	48	39	30	25	19	15	12	9.3
Electrical Time Constant	τ_e	ms	1.4	1.6	1.8	1.9	2.1	2.1	2.1	2.2
Mechanical Time Constant	τ_m	ms	5.3	4.4	4.1	3.9	3.5	3.5	3.4	3.3

¹Recorded at maximum winding temperature at 25°C ambient and without heatsink.

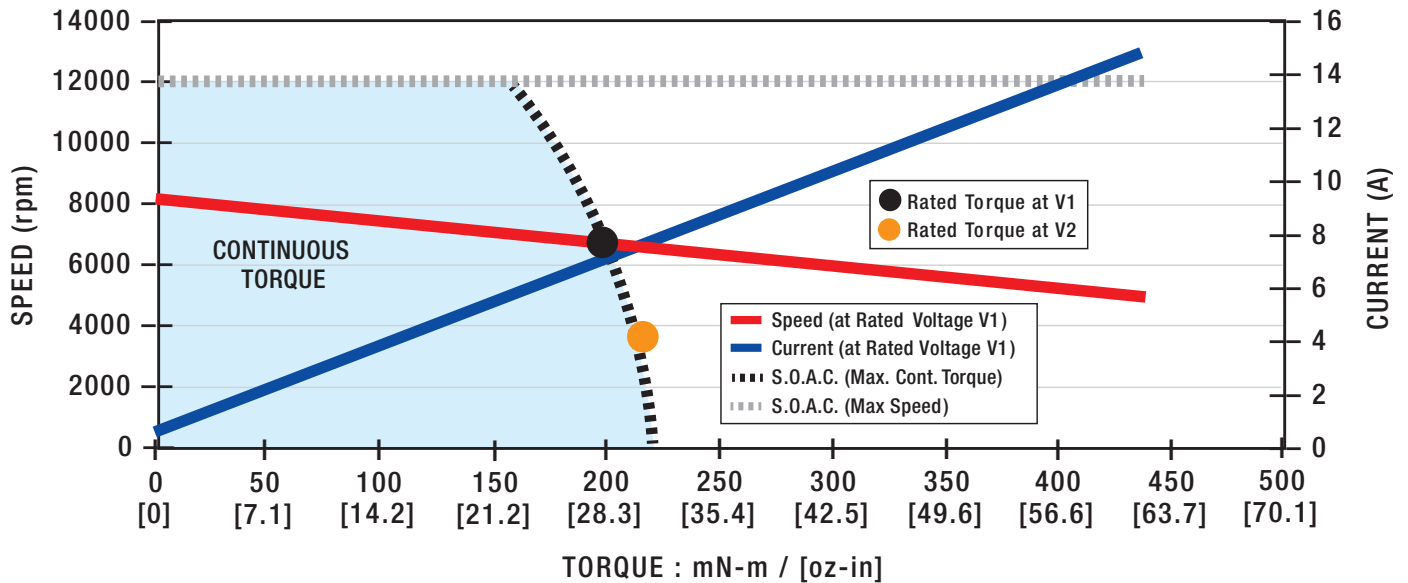

Motor Data		Units								
Rated Voltage V1	V _r	V	15.2	19.1	24.0	30.3	38.2	48.0	60.6	76.4
Rated Torque ¹ •	T _r	Nm	0.27	0.26	0.26	0.26	0.25	0.25	0.25	0.25
		oz-in	38	37	37	36	36	36	35	35
Rated Speed ¹	ω _r	rpm	5870	5850	6110	6270	6120	6280	6360	6190
Rated Current ¹	I _r	A	14	11	8.6	6.8	5.2	4.2	3.3	2.6
Rated Power ¹	P _r	W	170	160	170	170	160	170	170	160
No Load Speed	ω _{nl}	rpm	6750	6510	6650	6730	6530	6660	6720	6540
No Load Current	I _{nl}	A	0.66	0.50	0.41	0.33	0.26	0.21	0.17	0.13
Rated Voltage V2	V _r	V	9.55	12.0	15.2	19.1	24.0	30.3	38.2	48.0
Rated Torque ¹ •	T _r	Nm	0.28	0.28	0.28	0.28	0.28	0.28	0.28	0.28
		oz-in	40	40	40	39	39	39	39	39
Rated Speed ¹	ω _r	rpm	3100	3180	3410	3510	3430	3550	3600	3490
Rated Current ¹	I _r	A	15	11	9.2	7.3	5.6	4.6	3.6	2.8
Rated Power ¹	P _r	W	92	94	100	100	99	100	100	100
No Load Speed	ω _{nl}	rpm	4230	4080	4200	4230	4090	4200	4230	4100
No Load Current	I _{nl}	A	0.60	0.46	0.38	0.30	0.23	0.19	0.15	0.12
Motor Constant	K _M	Nm/√W	0.057	0.062	0.065	0.067	0.069	0.069	0.070	0.071
		oz-in/√W	8.1	8.8	9.1	9.4	9.7	9.8	9.8	10
Torque Constant	K _T	Nm/A	0.0213	0.0278	0.0342	0.0427	0.0555	0.0683	0.0855	0.111
		oz-in/A	3.02	3.94	4.84	6.04	7.86	9.67	12.1	15.7
Voltage Constant	K _E	V/(rad/s)	0.0213	0.0278	0.0342	0.0427	0.0555	0.0683	0.0855	0.111
		V/krpm	2.23	2.91	3.58	4.47	5.81	7.15	8.95	11.6
Terminal Resistance	R _{mt}	Ω	0.140	0.200	0.280	0.410	0.650	0.980	1.51	2.45
Inductance	L	mH	0.22	0.37	0.56	0.88	1.5	2.3	3.5	6.0
Peak Current	I _{pk}	A	48	36	29	24	18	15	12	9.0
Electrical Time Constant	τ _e	ms	1.6	1.9	2.0	2.1	2.3	2.3	2.3	2.4
Mechanical Time Constant	τ _m	ms	4.6	3.8	3.6	3.3	3.1	3.1	3.1	3.0

¹Recorded at maximum winding temperature at 25°C ambient and without heatsink.

